

SAVE VTR 150/K

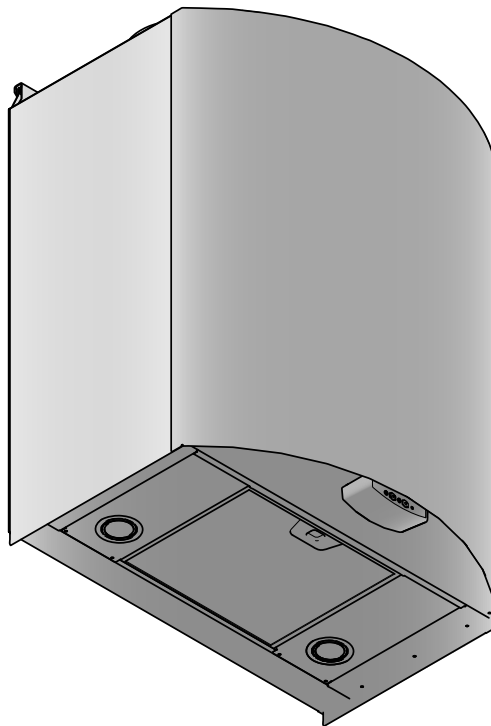

GB User Manual

© 2015 Copyright Systemair AB

Systemair AB can accept no responsibility for possible errors in catalogues, brochures and other printed material. Systemair AB reserves the right to alter its products without notice. This also applies to products already on order provided that such alterations can be made without sub sequential changes being necessary in specifications already agreed.

All rights reserved.

Contents

1 Disposal and recycling	1
2 Warnings	1
3 Introduction	2
4 Cooker hood	2
5 Configuration	3
5.1 Control panel	3
5.1.1 Display symbols	4
5.2 Setting the temperature	4
5.3 Manual setting of airflow	5
5.4 Programming the Week schedule	6
5.5 Manual and automatic summer mode	7
6 Cooker hood maintenance	7
6.1 Cleaning cooker hood	7
6.2 Changing halogen lamps	8
7 Maintenance of the unit	8
7.1 Warnings	8
7.2 Remove/mount the outer front	9
7.3 Remove/mount the inner front	9
7.4 Changing filters	10
7.5 Resetting the filter time	10
7.6 Checking and cleaning the heat exchanger	11
7.7 Cleaning the fans	11
7.8 Replacing rotor drive belt	13
7.9 Overheat protection reset button	14
8 Duct system maintenance	15
8.1 Cleaning extract louvres and supply air diffusers	15
8.2 Checking the outdoor air intake	15
8.3 Checking the roof cowl (if fitted)	15
8.4 Checking and cleaning the duct system	15
9 Trouble shooting	16
9.1 Alarm list	16
9.2 Type label	17

1 Disposal and recycling

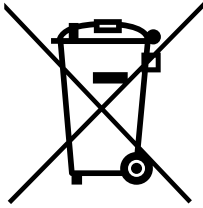

This product are applicable to the WEEE directive. When disposing the unit, follow your local rules and regulations.

This product packing materials are recyclable and can be reused. Do not dispose in household waste.



2 Warnings

The following admonitions will be presented in different sections of the document:

Danger

- Make sure that the mains supply to the unit is disconnected before performing any maintenance or electrical work!
- All electrical connections and maintenance work must be carried out by an authorized installer and in accordance with local rules and regulations.

Warning

- The system should operate continuously, and only be stopped for maintenance/service.
- The installation of the unit and complete ventilation system must be performed by an authorized installer and in accordance with local rules and regulations.
- Beware of sharp edges during mounting and maintenance. Use protective gloves.
- All though the Mains supply to the unit has been disconnected there is still risk for injury due to rotating parts that have not come to a complete standstill.
- Make sure that filters are mounted before starting the unit.
- This product must only be operated by a person which has suitable knowledge or education within this field or carried out with the supervision of a suitably qualified person.

Caution

- Do not connect tumble dryers to the ventilation system.
- Duct connections/duct ends must be covered during storage and installation.

3 Introduction

The SAVE VTR 150/K is a heat recovery ventilation unit with a built in rotating highly efficient heat exchanger and cooker hood. The SAVE VTR 150/K is suitable for smaller flats or houses. It supplies filtered outdoor air to residential areas and extract air from bathroom, kitchen and wet rooms. There are two model options, right (R) and left (L) model. Both models come with 500 W or 1000 W installed re-heater battery. The different models are recognized by the placing of the internal components. This manual describes basic information how to operate and perform maintenance on a left (L) unit and the system it is connected to.

Note:

This document describes a left (L) model. The inside of a right (R) model is mirrored.

4 Cooker hood

Danger

- Do NOT flambé beneath the cooker hood when in use.
- Sufficient air flow must be secured to the room when the cooker hood is in use

Press button A to turn on the lights.

Press button B once to open the ventilation damper when cooking. The LED indicator (C) is steadily lit.

Press button B again to force the ventilation. The LED indicator is blinking.

Press button B a third time to close the ventilation damper. The ventilation fan goes back to nominal speed and the LED indicator goes off.

The damper will automatically close after 60 minutes unless it is manually closed.

No extract air will go through the cooker hood in "off" mode. Extract air from the kitchen needs a separate air valve.

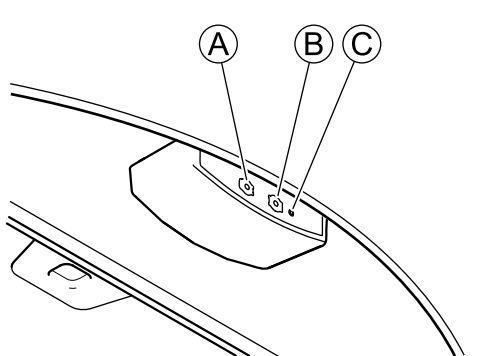

Fig. 1 Cooker hood front panel

Hint: Let the damper be open a while before and after cooking to prevent smoke from spreading in the room.

5 Configuration

5.1 Control panel

Connect the unit electrically to the mains with the enclosed plug and check that it starts up correctly.

The control panel is used to make the necessary adjustments.

An external control panel can be connected on the top of the unit.

The illustration below shows the control panel with a short description.

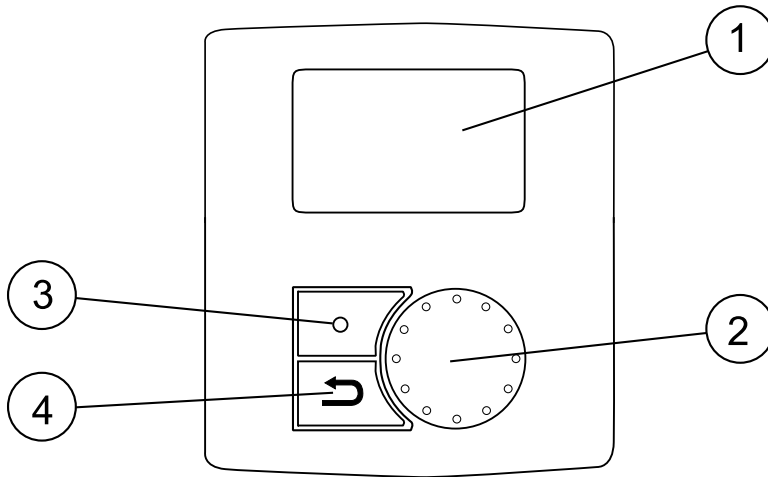
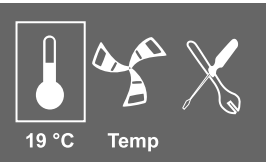
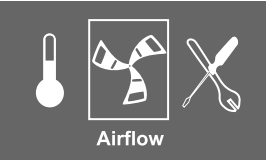





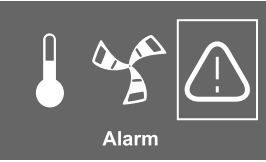

Fig. 2 Control panel

Position	Description	Explanation
1	Display	Shows symbols, menus and settings
2	SELECTION knob	Move through the menu lists or change settings and values by turning the knob left or right
3	ENTER button	ENTER menu choices or settings by pressing the button
4	RETURN button	Step RETURN in the menu levels and to abort an initiated parameter change and restore the original value by pressing the button

5.1.1 Display symbols

Symbol	Description	Explanation
	Temp	<p>Illustrates the current set-point for supply air temperature (from completely empty to filled symbol).</p> <p>Turn the SELECTION knob to choose temperature.</p> <p>Press ENTER to save the setting.</p>
	Airflow	<p>Illustrates the current airflow. The airflow can be set manually in 5 steps: Off, Low, Nom, High and Auto.</p> <p>Turn the SELECTION knob to choose airflow.</p> <p>Press ENTER to save the setting.</p> <div style="display: flex; justify-content: space-around; align-items: center;">      </div> <p style="text-align: center;">A B C D E</p> <p>A. Ventilation off.¹</p> <p>B. Low ventilation: Can be used when leaving the building for a longer period</p> <p>C. Nominal ventilation: Will give required air change under normal conditions.</p> <p>D. Maximum ventilation: To increase the airflow if necessary.</p> <p>E. Auto ventilation: Will regulate after the pre-setting for the demand control settings.</p>
	Service	Press ENTER to access the service menu.
	Alarm	Press ENTER to access the alarm list.

1. The fan can be set to OFF by activating manual fan stop. See service menu description under functions.

Important

It is not recommended to activate manual fan stop (set fan to OFF) in standard households. If manual fan stop is activated, the unit should be provided with dampers in exhaust and fresh air ducts to avoid cold draught and risk of condensation when the unit has been stopped.

5.2 Setting the temperature

The supply air temperature is set manually in steps of 1 K in the main menu display by choosing the temperature symbol.

If an electrical re-heater is installed the temperature setpoints are: 12-22 °C. For installed water re-heater the setpoints are: 12-40 °C.

If the re-heater is deactivated, the temperature steps are:
15-19 °C. Default value: 15.0 °C.

Each temperature step is illustrated by increasing the filling of the temperature symbol and the temperature is shown in the display

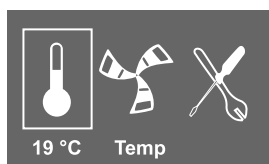

An unfilled temperature symbol will activate manual summer mode. See chapter 5.5

5.3 Manual setting of airflow

It is possible, at any time, to manually set the airflow in the main menu display. By choosing the fan symbol and confirming, it is possible to increase or decrease the airflow in 5 steps: Off, Low, Nom, High and Auto.

By doing so, you override the programmed week schedule for the unit until the end of the present time period in the week program (chapter 5.4).

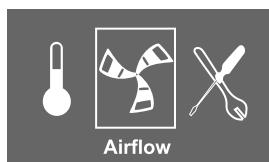

Warning

It is **not** recommended to activate manual fan stop (set fan to OFF) in standard households. If manual fan stop is activated, the unit should be provided with dampers in exhaust and fresh air ducts to avoid cold draught and risk of condensation when the unit has been stopped.

The fan can be set to OFF by activating manual fan stop. See the Installation and Service manual, chapter Service menu overview: *Manual fan stop*.

5.4 Programming the Week schedule

Set the week schedule according to below procedure:

<p>1. Go to the service menu by using the SELECTION knob.</p>	
<p>2. Enter the service level by typing the password, default 1111. Use the SELECTION knob for each digit and confirm with the ENTER button after each set digit and choose "NO" for the system not be locked.</p>	<p>Password Password XXXX Locked YES/NO</p>
<p>3. Go to: Week program</p>	<p>Service Week program</p>
<p>4. Choose Week program again.</p>	<p>Week program Airflow</p>
<p>5. Set week day and time you want the unit to be in ON level. Two periods per day can be programmed. The rest of the time the unit will be in OFF level.</p>	<p>Week program Day: MON Per 1: 07:00 16:00 Per 2: 00:00 00:00</p>
<p>6. Go back to the previous dialogue frame with the RETURN button and go down to Airflow.</p>	<p>Week program Airflow</p>
<p>7. Set which airflow the fan is supposed to be running in the ON level, choose between Low, Nom, High or Auto.</p> <p>Set which airflow the fan is supposed to be running in the OFF level, choose between OFF, Low, Nom or High.</p> <hr/> <p>Note:</p> <p>If an electrical re-heater battery is installed and active and the unit is shut down from the control panel, for example by choosing OFF. When the unit is in OFF level in the week program, the fans will continue to run for 3 minutes, to prevent the heater from triggering the over heat protection sensor, before they stop.</p> <hr/>	<p>Airflow On level: low/nom/high/auto Off level: off/low/nom/high</p>
<p>8. Step back with the RETURN button until you reach the main menu display</p>	

5.5 Manual and automatic summer mode

Manual summer mode occurs if no temperature step is selected. The temperature symbol on the main menu is then completely empty.

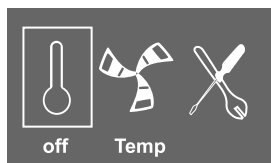

If the electrical re-heater is activated, it will switch off during manual summer mode. Manual summer mode goes automatically to step 1 (setpoint 12 °C) after two minutes if the supply air temperature is +5 °C or below.

If a water heater battery is installed and activated, the manual summer mode goes automatically to step 1 (setpoint 12 °C) if the outdoor air or supply air temperature is +5 °C or below.

The unit will automatically alternate between winter operation with heat recovery and summer operation without heat recovery.

6 Cooker hood maintenance

6.1 Cleaning cooker hood

Warning

There is fire hazard if the cooker hood is not cleaned within given intervals.

- The filter is to be cleaned every second month during normal use. Clean more often during intense use.
- Clean the inside of the cooker hood at least twice a year.

Remove the filter as shown in the image:

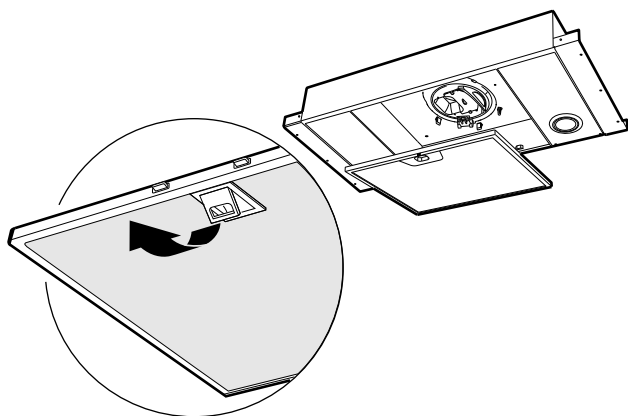

Fig. 3 Remove cooker hood filter

The metal grease filter can be cleaned in a dishwasher or by hand using a mild detergent or liquid soap. When replacing, ensure that it is dry.

The other parts of the cooker hood are wiped with a damp cloth and mild liquid household cleaner. Never use abrasive cleaning materials.

6.2 Changing halogen lamps

Warning

The lamps may be hot! Risk of burn injuries.

Switch off the power and let the lamps cool down.

Pull down the metal ring securing the lamp glass.

The lamp can now be changed. (Halogen lamp 12V 20W socket G4) Use a cloth, or similar, to avoid direct contact with the lamp.

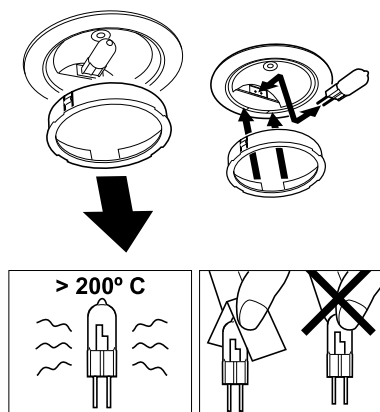

Fig. 4 Change cooker hood lamps

7 Maintenance of the unit

Maintenance of the SAVE VTR 150/K should normally be performed 3 - 4 times a year.

7.1 Warnings

Danger

- Make sure that the mains supply to the unit is disconnected before performing any maintenance or electrical work!
- All electrical connections and maintenance work must be carried out by an authorized installer and in accordance with local rules and regulations.

Warning

- The system should operate continuously, and only be stopped for maintenance/service
- Although the mains supply to the unit has been disconnected there is still risk for injury due to rotating parts that have not come to a complete standstill
- Beware of sharp edges during maintenance. Use protective gloves
- Make sure that filters are mounted in their place before running the system
- This product must only be operated by a person which has suitable knowledge or education within this field or carried out with the supervision of a suitably qualified person.

7.2 Remove/mount the outer front

The outer front is mounted with four pins and is removed by pushing the locking hock to the left and pulling the front towards you.

To re-mount the outer front, place the front on the cooker hood and push it forward.

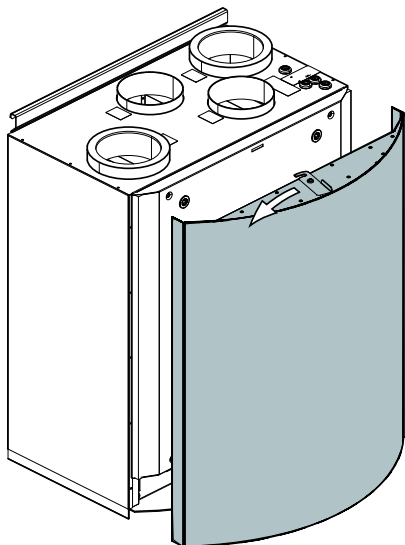

Fig. 5 Outer front

7.3 Remove/mount the inner front

The inner front is mounted with four screws. Loosen the screws and pull the inner front towards you.

Mount the inner front and tighten the mounting screws properly to prevent air leakage.

Note:

When re-mounting the inner front, note the two guide screws at the bottom of the inner front. These screws shall be fitted into the two slots in the inner hatch support bracket.

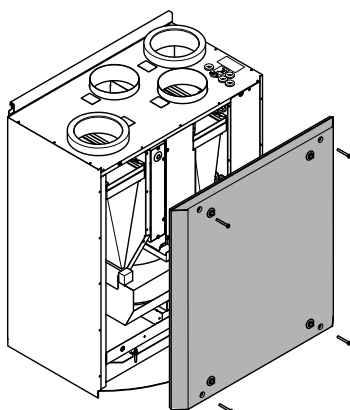

Fig. 6 Inner front

7.4 Changing filters

Danger

Make sure that the Mains supply to the unit is disconnected before performing any maintenance or electrical work!

The filters are to be changed every 6/9/12/15 months, default value is 12 months. When the filters have been changed the filter timer must be reset. See 7.5 *Resetting the filter time*

The factory installed filters are of filter quality G3 for both the supply air and extract air filter. The filters need to be replaced when polluted. New sets of filters can be acquired from your installer or wholesaler.

Filter quality F7 can be installed for supply air filtering.
The filter type is labelled on the top of the filter.

Caution

If type F7 filters are changed, the heat recovery system may need re-configuration to function optimally. If filter F7 are used instead of G3, the system curve for Supply Fan (SF) must be changed:

For G3 type filter: 1–10, for F7 type filter: 11–20. See Installation and Service Instruction.

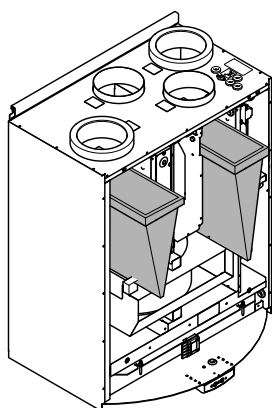



Fig. 7 Heat exchanger filters

7.5 Resetting the filter time

<p>1. Go to the service menu by using the selection knob.</p>	 <p>Service</p>
<p>2. Enter the service level by typing the password. Use the SELECTION knob for each digit and confirm with the ENTER button after each set digit and choose "NO" for the system not be locked.</p>	<p>Service ->Password Locked YES/NO</p>
<p>3. Go to: Filter period, press ENTER. Choose: Reset: YES with the SELECTION knob and then ENTER. Change, if necessary, Time to replace X month, to the time of your choice with the SELECTION knob and then press ENTER.</p>	<p>Filter period Time to replace: 6/9/12/15 month Reset NO/YES</p>

Press the RETURN button until you reach the main menu.

7.6 Checking and cleaning the heat exchanger

Danger

- Make sure that the Mains supply to the unit is disconnected before performing any maintenance or electrical work!

Even if the required maintenance is carried out, dust will build up in the exchanger block. It is therefore of vital importance for the upkeep of a high efficiency that the exchanger block is removed from the unit and cleaned periodically as illustrated below. Clean the heat exchanger at least every 3 years or when required.

1. Disconnect the rotor power supply and the rotor sensor. The cables are found beside the rotor at the back.
2. Pull out the rotor towards you. Some force may be needed.
3. Clean the rotor.

Wash in hot soapy water. Do not use detergent containing ammonia. Rinse using, for instance, a shower handle.

Warning

Ensure the rotor motor is not exposed to moisture

4. Remount the rotor. Don't forget to reconnect the rotor power and sensor cables.

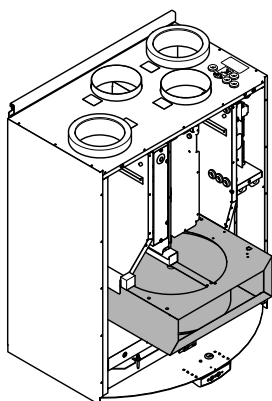

Fig. 8 Heat exchanger

7.7 Cleaning the fans

Danger

- Make sure that the Mains supply to the unit is disconnected before performing any maintenance or electrical work!

The motor bearings are life time lubricated and maintenance free.

Even if the required maintenance, such as changing of filters is carried out, dust and grease may slowly build up inside the fans. This will reduce the efficiency.

The fans may be cleaned as illustrated in below procedure.

1. Disconnect the fan power cables. The cables are found beside the fan at the back.
2. Pull out the fans towards you. Some force may be needed.

3. Clean the fans with a cloth or a soft brush. Do not use water. White spirit can be used to remove obstinate deposits.

Allow the fans to dry properly before remounting.

4. Remount the fans. Don't forget to reconnect the fan power cables.

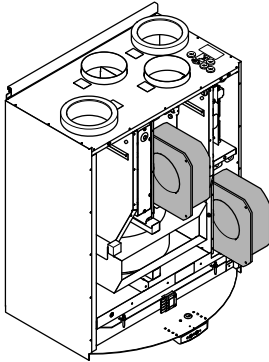

Fig. 9 Extract and supply air fans

7.8 Replacing rotor drive belt

If the alarm `ROTOR` is raised, see chapter 9.1, the rotor drive belt may be damaged or broken.

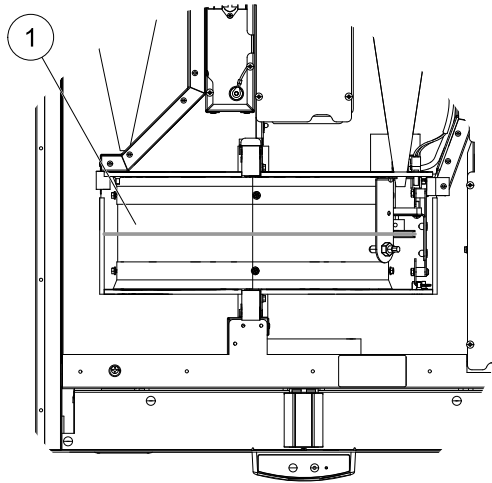

Fig. 10 Rotor drive belt

The replacement drive belt (1) is adjustable and delivered with a nipple attached in one end.

1. Stop the unit by disconnecting the mains.
2. Open and remove the side cover.
3. Remove the broken drive belt.
4. Use tape to attach the drive belt to the rotating heat exchanger, and rotate the exchanger by hand to get hold of the drive belt.
5. Remove the tape and put the "empty" end on to the nipple. Press the ends firmly towards each other and tighten the nipple.
6. Pull the drive belt on to the belt pulley and rotate the exchanger by hand. Check that the belt pulley rotates.

Note:

If the drive belt slips, the drive belt may be too long and needs to be shortened. Cut the drive belt 5 mm and go to step 5.

7. Replace and lock the side cover and connect the unit to mains.
8. Check that the alarm has ceased on the Control Display.

Note:

If the alarm remains, check the rotor sensor.

7.9 Overheat protection reset button

If the supply air temperature is low, it can indicate that the over heat protection is triggered. The overheat protection can be reset by pressing the reset button.

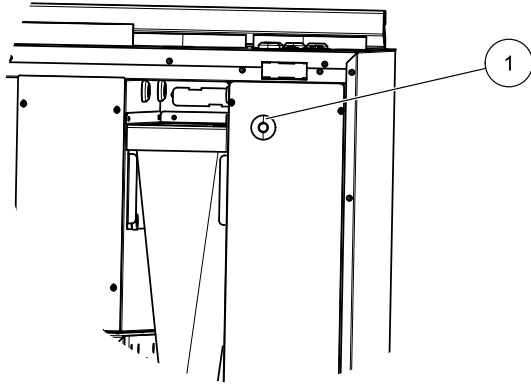

8 Duct system maintenance

8.1 Cleaning extract louvres and supply air diffusers

The system supplies fresh air to your home and extracts the used indoor air via the duct system and diffusers/louvres. Diffusers and louvres are mounted in ceilings/walls in bedrooms, living room, wet rooms, WC etc. Remove diffusers and louvres and wash in hot soapy water as required (diffusers/louvres must not be exchanged). Cleaning of diffusers/louvres can be done as necessary.

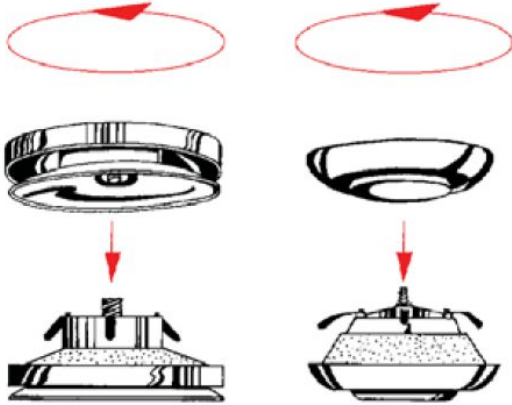

Fig. 11 Diffusers and louvres

8.2 Checking the outdoor air intake

Leaves and pollution could plug up the air intake grille and reduce the capacity. Check the air intake grille, and clean as necessary. It is recommended to do this at least twice a year.

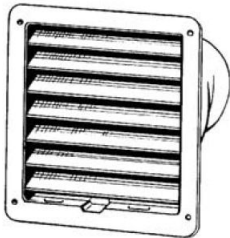

Fig. 12 Intake grill

8.3 Checking the roof cowl (if fitted)

The roof cowl (if fitted) connected to the exhaust air duct needs to be checked at least twice a year and cleaned if necessary.

8.4 Checking and cleaning the duct system

Dust and grease deposits may build up in the duct system, even if required maintenance such as changing of filters is being carried out. This will reduce the efficiency of the installation.

The duct runs should therefore be cleaned/changed when necessary. Steel ducts can be cleaned by pulling a brush soaked in hot soapy water through the duct via diffuser/louvre openings or special inspection hatches in the duct system (if fitted).

It is recommended to do this every 5 years and is normally carried out by authorized companies specialized in this area.

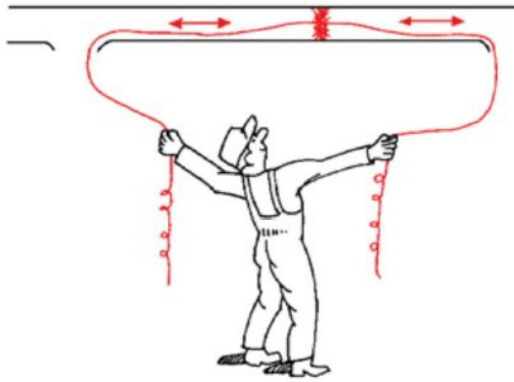

Fig. 13 Cleaning duct system

9 Trouble shooting

A warning triangle with text in the display indicates an alarm. Turn menu selector to the warning triangle and press confirm twice to view the alarm.

9.1 Alarm list

Alarm	Explanation	Do the following
Fan	Indicates error on either supply or extract air fan.	<p>The alarm is displayed in the control panel.</p> <p>Check that quick connectors are connected for the both fans.</p> <p>Contact your installation company or place of purchase.</p>
EMT/Frost	Indicates triggered frost protection (in case of installed water heating battery) or triggered overheat protection (in case of installed electric re-heater battery).	<p>A triggered frost protection alarm results in the following:</p> <ul style="list-style-type: none"> • Both fans stop. • Outdoor and exhaust air dampers closed. • Water valve opens completely (10 V signal goes out to the actuator). <p>The unit will restart once the water temperature reaches +5°C above the set frost protection temperature.</p> <p>A triggered over heat protection (EMT) gives an alarm in the control panel.</p> <p>Reset by pushing the reset button. See chapter 7.9.</p> <p>If the problem continues contact your installation company or place of purchase.</p>

Alarm	Explanation	Do the following
Rot	Indicates a rotor malfunction.	<p>The alarm is displayed in the control panel.</p> <ul style="list-style-type: none"> • If the rotating heat exchanger has stopped. Check the rotor belt. See chapter 7.8 • If the heat exchanger is still rotating, check that the quick connector for the sensor is connected and that there is an air gap of 5-10mm between the sensor and the magnet. <p>Adjust the gap if necessary.</p> <p>If the alarm persists, the rotor sensor may be faulty.</p> <p>Contact your installation company or place of purchase.</p>
Pb Fail	<p>Error in connection with relay card for the electrical re-heater (if installed and activated).</p> <p>The overheat protection sensor, automatic reset (ET2) may be triggered due to high temperature.</p>	<p>The alarm is displayed in the control panel.</p> <p>The heater will not be activated.</p> <p>For triggered ET2, wait 10–15 min. If the error remains, contact your installation company or place of purchase.</p>
Temp	Malfunction in one or more of the temperature sensors.	<p>The alarm is displayed in the control panel.</p> <p>Contact your installation company or place of purchase.</p>
Filter	Time for filter change.	<p>The alarm is displayed in the control panel.</p> <p>Change filter according to the instructions in the User Manual.</p>
Low SS	Indicates low supply air temperature	<p>The alarm is displayed in the control panel.</p> <p>If water reheater is configured and frost protection have failed, then an extra security function is triggered when supply air temperature is lower than 5 °C and outdoor air temperature is below 0 °C.</p>
RH	Indicates malfunction of internal relative humidity sensor.	<p>The alarm is displayed in the control panel.</p>

9.2 Type label

Before calling your service representative, make a note of the specification and production number from the type label, which can be found on the side of the units, next to the external connections.

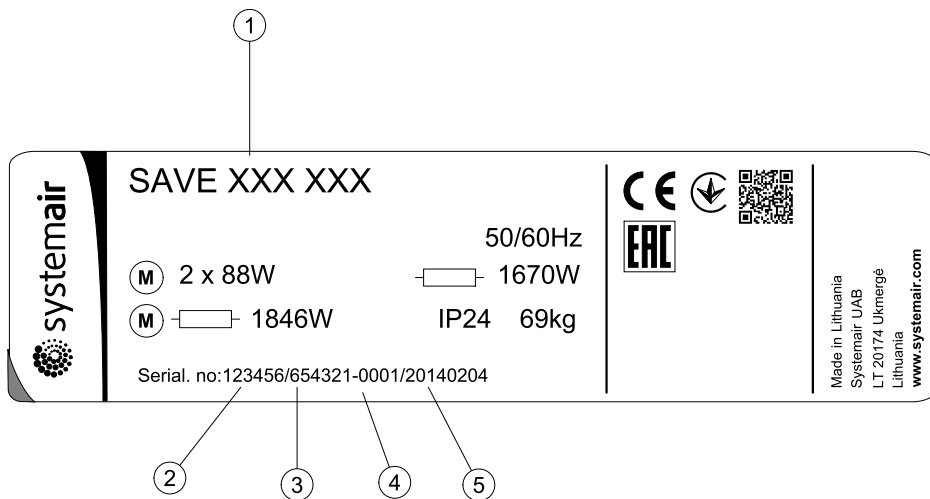

Fig. 14 Type label

Position	Description
1	Product code (product specification)
2	Product item number
3	Production order number
4	Serial number
5	Production date (YY.MM.DD)

Systemair Sverige AB reserves the right to make changes and improvements to the contents of this manual without prior notice.



Systemair UAB
Linių st. 101
LT-20174 Ukmergė, LITHUANIA
Phone +370 340 60165
Fax +370 340 60166
www.systemair.com